



Tips and Techniques for Making Power Supply Noise Measurements with an Oscilloscope

Application Note 1592

Introduction

The electronics in today's designs feature higher-speed switching, faster slew rates, more active pins per package, and smaller signal swings than ever before. As a result, designers are more concerned about power supply noise in new digital designs, in everything from cell phones to servers. Real-time oscilloscopes are commonly used to measure power supply noise. This application note illustrates techniques for analyzing power supply noise and discusses selection and evaluation of tools for power supply noise measurements.

The problem

As switching speeds and signal slew rates increase, and as the number of active pins on devices increase, more switching noise is induced in power supplies.

At the same time, circuits are becoming more susceptible to power supply noise. Decreased unit intervals mean shrinking timing margins. Reduced signal amplitudes translate to reduced noise margins.

As with all engineering problems, understanding the problem and having accurate and precise measurement data to characterize the problem are essential to solving it.

Insights to "noise"

Ideally, there wouldn't be any noise on your power supplies. How did it get there?

In addition to simple Gaussian noise generated by unavoidable thermal processes – which usually is *not* the dominant source of noise – almost all noise on power supplies comes from one of two sources.

Switching power supplies create their own undesired noise, usually at harmonics of the switching frequency or coherent to the switching frequency.

When gates and output pin drivers switch, this action creates transient current demands on the power supplies. This is usually the primary source of noise in most digital circuits. These switching events may appear random in time; however, they tend to be coherent with clocks in the system.

Once we realize we can think about these influences as "signals" superimposed on the power supply instead of thinking about them as "noise," the analysis becomes much simpler and more powerful.



Measurement challenges

Because of the wide bandwidth of power supply noise, designers tend to choose oscilloscopes for measuring it. Oscilloscopes can also provide unique insights into the cause of noise, as we will illustrate.

Real-time, wideband digitizing oscilloscopes and wideband scope probes have their own noise, which you must take into account. If the noise you're trying to measure on your power supply is of the same order as the noise floor of the scope and probe, you are challenged to measure your noise accurately. This application note will discuss techniques you can use to extract information below the scope's noise floor.

Another problem is dynamic range. Your power supply is at some DC voltage. The small AC noise riding on it is usually a tiny fraction of the DC level. With some scopes and probes, you may face a challenge in offsetting the scope and probe sufficiently to allow you to use a more sensitive range to get a better view of the noise and at a lower scope noise level. See sidebar "A brief lesson in scope noise."

A brief lesson in scope noise

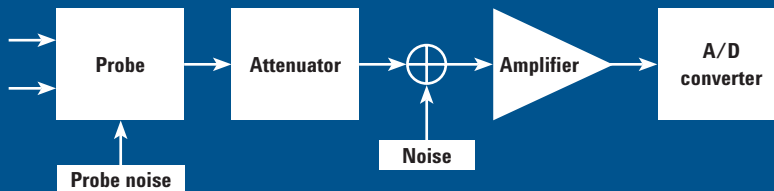

Figure 1. Noise sources

Refer to the block diagram shown in Figure 1. There are two principal sources of noise in an oscilloscope and probe system. The input amplifier and buffer circuits in the scope contribute some noise, and the probe amplifier has noise inherent in its design.

All scopes use an attenuator to vary the vertical scale factor. The scope's noise arises after this attenuation occurs. So when the attenuator is set to any ratio other than 1:1 (i.e. the scope's most sensitive hardware range), the noise will appear to be larger relative to the signal at the input connector. For example, consider a scope that has a basic sensitivity of 5 mV/division with no attenuation inserted. Assume it has a noise floor on the 5 mV/div range of 500 microvolts RMS. To change the sensitivity to 50 mV/div, the scope inserts a 10:1 attenuator in series with the input. The noise then appears as if it were 5 mV RMS relative to the input (500 microvolts times 10).

Therefore there is an advantage to using the most sensitive range possible to avoid "magnifying" the scope's noise unnecessarily.

The noise introduced by the probe is introduced before the scope's input attenuator, so it will always contribute the same to the measurement regardless of the scale factor.

Measurement challenges (continued)

In most cases the probe noise is significantly larger than the scope's noise on the most sensitive range, so you might ask, why use a probe? Most power supplies can drive the 50-ohm input on a scope with no problem, so why add the probe's noise into the measurement unnecessarily? The answer has to do with dynamic range. Let's consider an example. To measure the noise on a 1.5-VDC supply, you would like to use 1.5 V of offset to get the signal centered on screen and also centered on the range of the scope's A/D converter. The most sensitive range on which the scope will allow 1.5 V offset is the 100-mV/division range. On the 100-mV/div range, the scope's noise will be ~3 mV RMS. On the 100-mV/div range, the noise you're measuring will only exercise a small portion of the range of the A/D converter, so you would sacrifice resolution in the measurement.

By using an active differential probe, you can offset the signal by 1.5 VDC, thereby allowing you to use the 10-mV/div range for the measurement. For a more complete discussion of the advantage of using offset in probes for this type of measurement, refer to "Understanding and Using Offset in InfiniiMax Active Probes," Agilent Application Note 1451 at <http://cp.literature.agilent.com/litweb/pdf/5988-9264EN.pdf>.

The dynamic range problem can also be overcome by using AC coupling, if your scope (or probe) allows AC coupling. If you're using a scope that has 50 ohm inputs (such as the Agilent DSO80000), and you want to use a 50-ohm coax with a "1:1 probe" as described on page 8, you can use a series blocking capacitor. Select the blocking capacitor size that will allow you to view the lowest significant

frequency you anticipate in the spectrum of the noise.

The only downside of AC coupling is that you will not be able to see slow drift of the power supply voltage.

An example

To simulate a power supply with controllable sources of noise for this experiment, we set up a laboratory power supply with some noise sources, as shown in Figure 2.

The square wave generator simulates switching noise coming from pin drivers and other transient load conditions. The sine wave generator simulates noise from a switching power supply. We also added some truly random noise just to make it harder to see and measure the coherent noise sources.

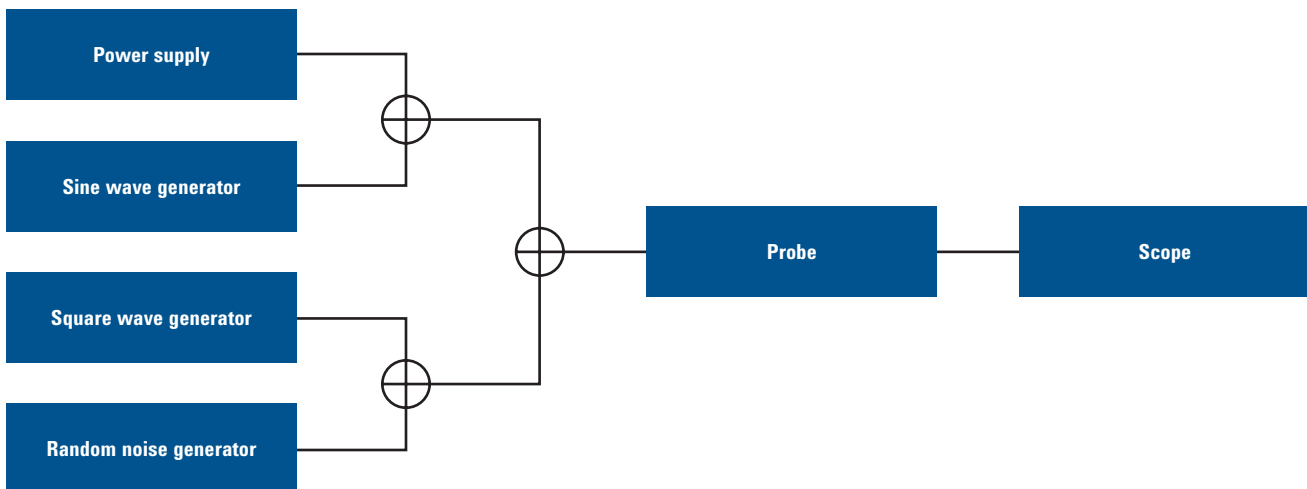

Figure 2. Experimental setup

Measurement challenges (continued)

First, we characterized the noise generated by the measurement system, which consisted of the scope and probe. Figure 3 shows the noise measured on the scope with nothing attached to the probe input. The noise measures on the order of 800 microvolts RMS. This tells us if we try to measure noise on the order of 2.4 mV RMS or less, the results will

be somewhat questionable, depending on the nature of the noise we're measuring. Noise with a Gaussian pdf adds in quadrature, so if we measured truly Gaussian noise that was 2.4 mV RMS, the measured answer would be the square root of 2.4 mV squared plus 800 microvolts squared, or 2.53 mV, an error of ~5%.

If, on the other hand, the "noise" is bounded and coherent, we can make accurate measurements on smaller amplitudes.

Figure 4 shows the "noise" with all three noise sources applied: sine wave, square wave, and random. There is little usable analytical information in this view.

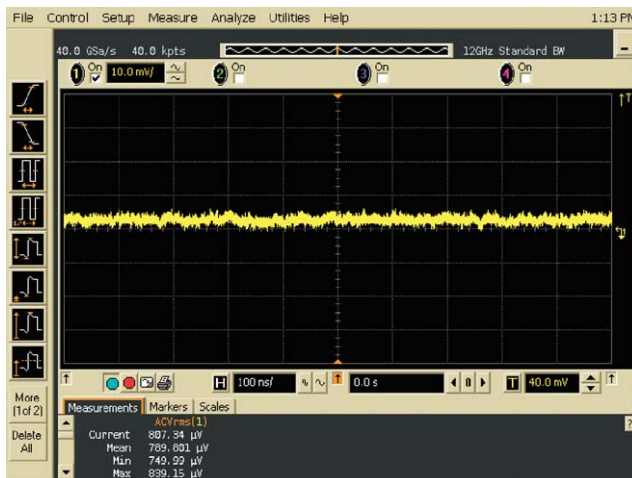

Figure 3. Scope and probe noise



Figure 4. Power supply with noise

Tip 1 Use the frequency domain for analysis

An FFT analysis will provide more insight into this signal, as you'll see in Figures 5 and 6 (also see sidebar, "FFT considerations in scopes"). Two components are apparent in addition to the broadband "white" noise: a component at a frequency of 49.5 MHz and another at 500 MHz.

The FFT can give you quick analytical insight into where your noise is coming from. For example, if you have a 33-KHz switching power supply and a 500-MHz clock, you may see spurs at 33 KHz and at multiples of 500 MHz. The relative amplitude of these spurs will give you some first-order insight into how much unwanted noise power each is contributing.

Another technique to improve visibility of the spurs is to average the FFT. The true random noise will be greatly suppressed by averaging the FFT, allowing you to pull very tiny signals out of the noise.

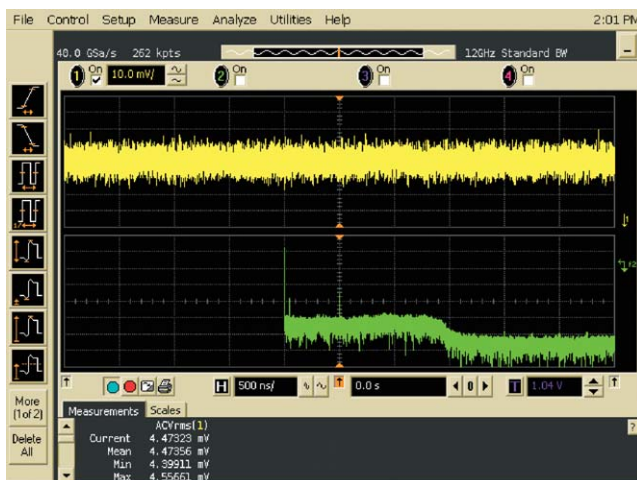

Figure 5. FFT of power supply noise

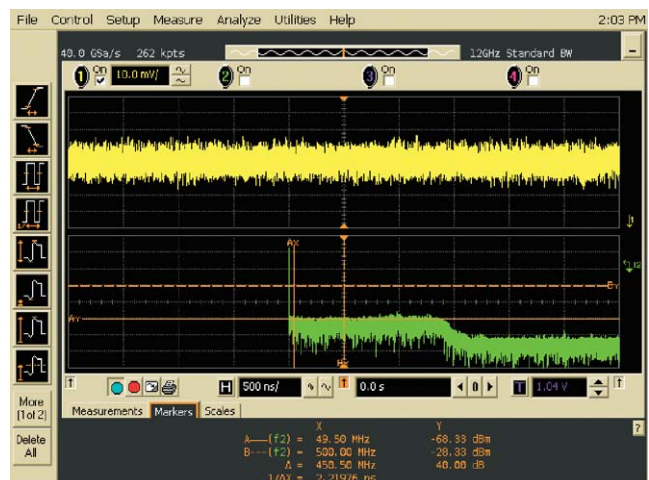

Figure 6. FFT with markers

Tip 2 Use triggering to view and measure signal components

If you can trigger on any signal that is phase-coherent with either of the non-random sources and then use averaging, all components that are not correlated to that signal will be reduced or eliminated. Figures 7 and 8 illustrate this technique. In Figure 7, the scope is triggered on the 500-MHz sine wave and averaging is turned *on* with 64 averages. The purple trace

is the 500-MHz source, applied to a second channel on the scope. That channel is the trigger source. The yellow trace shows the power supply noise after all the components that are not correlated to the 500-MHz signal are removed by averaging.

In Figure 8 the scope is triggered on the 49.5-MHz square wave. Now you

see only the components of the noise that are correlated to the 49.5-MHz square wave.

This technique allows you to view and measure signal components that are swamped by the random noise coming either from the power supply itself or from the scope and probe.

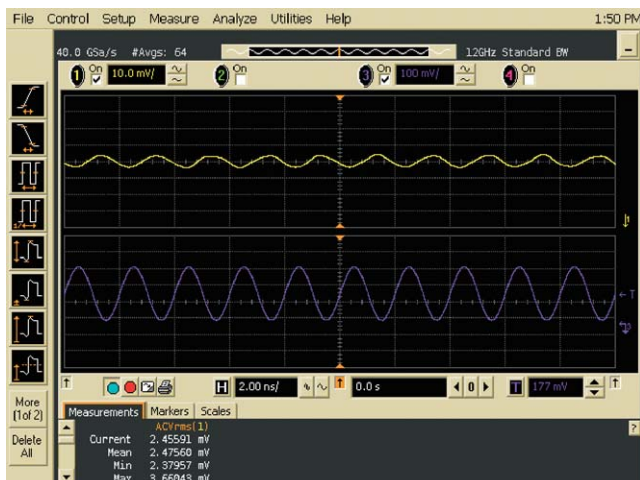

Figure 7. Scope triggered on sine wave, using averaging

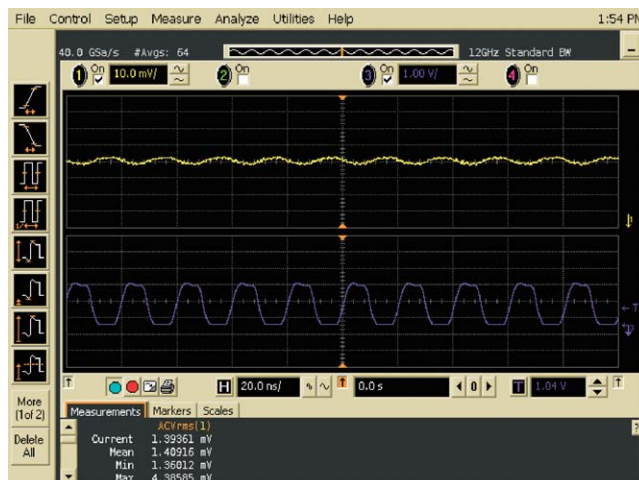

Figure 8. Scope triggered on square wave, using averaging

Tip 3 Use probe offset to increase dynamic range

In this example the power supply voltage is +1.5 VDC, and the noise is in the mV range. The DSO80000 scope by itself can only provide offset of 1.5 VDC on the 100 mV/div and higher ranges. You can use a more sensitive range to make more accurate measurements on the signal and to reduce the impact of scope noise on the measurement.

Agilent InfiniiMax active probes provide a greater range of offset than other probes, so you can use a more sensitive range in the scope and get better results. Refer to "Understanding and Using Offset in InfiniiMax Active Probes," Agilent Application Note 1451, <http://cp.literature.agilent.com/litweb/pdf/5988-9264EN.pdf>, for more information.

Building a special probe

Most power supplies will easily drive a 50-ohm load. A 50-ohm load will only draw 3 mA from a 1.5-V power supply. This allows you to connect a 50-ohm coax cable directly to your power supply and use a scope with a 50-ohm input for maximum sensitivity, instead of using a 10:1 probe. You can also use

this with a coaxial blocking capacitor, or with the Agilent N5380A dual-SMA differential probe head as described below. A 1:1 probe can be made fairly easily by stripping back the end of a short piece of semi-rigid coax cable and soldering a short ground wire to

one side, as shown in Figure 9. For improved ease of use, you can also use a small pogo pin instead of a wire for the ground connection. Pogo pins are available from Mill-Max (www.mill-max.com) and other vendors.



Figure 9. A 1:1, 50-ohm probe

The ultimate test configuration

The configuration described in this section provides all of the following:

- Lowest noise with wide offset capabilities
- Best signal-to-noise ratio with wide offset capabilities
- True differential measurement
- DC response (no AC coupling)

Use two 1:1 probes as described above, connected to the Agilent N5380A dual-SMA probe head, connected in turn to the Agilent 1168A probe amplifier, connected in turn to an Agilent DSO80000 oscilloscope.

Dissecting each element of this solution:

- The N5380A has lower noise when used with any InfiniiMax probe amplifier than other probe heads. For example, the typical noise of the N5380A/1168A combination is 1.6 mV RMS, compared to 2.5 mV RMS when used with other probe heads.
- The 1168A and 1169A probe amplifiers have lower noise than the 1130 Series probe amplifiers.
- The DSO80000 scope has the lowest noise of any scope available, and the noise can be further reduced by adjusting the bandwidth.

Summary of techniques and best practices

Know how much noise your scope and probe contribute. Select a scope and probe with sufficiently low noise floor to allow you to make your measurement accurately. Always use a differential probe.

Use probe offset to increase dynamic range.

Use FFT for analytical insight.

Trigger on suspect sources and use averaging to eliminate uncorrelated noise.

Noise measurement tools

The Agilent DSO80000B Series oscilloscopes have the lowest noise floor on the market and sufficient

bandwidth to make accurate measurements on power supplies in high-speed digital systems. Their noise is typically <400 microvolts RMS on the most sensitive range at 12 GHz bandwidth, less at lower bandwidths. With the bandwidth reduction option, you can eliminate some of the scope's noise by trading off bandwidth. The FFT will usually show you how much bandwidth you need to make the measurement accurately.

Differential probes are always to be preferred for small signal measurements, including power supply noise measurements. "Ground" is a convenient fantasy invented by engineers to simplify life. See "Performance Comparison of Differential and Single-Ended Active

Voltage Probes," Agilent Application Note 1419-03, available at <http://cp.literature.agilent.com/litweb/pdf/5988-8006EN.pdf>, for more background on the topic of single-ended versus differential probes.

The Agilent 1168A and 1169A differential probes have typical noise floor of 2.5 mV RMS and a bandwidth of 10 or 12 GHz.

The Agilent 1153A differential probe has a remarkably low noise floor of 200 microvolts RMS. It has the added advantages of 1:1 gain, resulting in maximum overall sensitivity, and it has a very wide offset range of ± 18 VDC. Its bandwidth is 200 MHz, which is sufficient for many power supply noise measurements.

FFT considerations in scopes

Most real-time digitizing scopes have a built-in FFT function. The scope will capture a finite amount of time on each trigger, based on the amount of memory and the sampling rate. The FFT cannot "see" frequencies in the incoming signal that are below the inverse of the scope's time capture window. The lowest frequency that can be analyzed by the FFT is $1/[1/(\text{sampling rate}) \times (\text{memory depth in samples})]$. To see a suspect source in the FFT, be sure you set the memory depth to capture enough samples. For example, if your switching power supply operates at 33 KHz, you would need to capture $1/(33 \text{ KHz})$ or 30 microseconds of signal activity in order to see it in the FFT. For a sampling rate of 20 GSa/s, this would require 600,000 points in memory.

In Agilent 8000 Series DSOs and DSO80000 Series scopes, the FFT operates only on the data that is on the screen. In order to see the lowest frequencies possible for the memory and sampling rate you have chosen, you must set the time base so all the memory is on screen. This is easily determined by referring to the memory bar above the graticule.

Summary of techniques and best practices (continued)

RMS or P-P?

Measurements are stated in RMS volts throughout this document. For signals with a Gaussian pdf, peak-to-peak is not defined and not repeatably measurable. RMS is well defined. For a Gaussian probability density function (pdf), the definition of RMS is identical to standard deviation, so tables of statistics can be used to relate the probability of a Gaussian noise signal with a known RMS value exceeding any given peak value. If you add two noise signals, each with a Gaussian distribution, the standard deviation of the combination will not be the sums of the individual standard deviations, but rather the square root of the sum of the squares of the individual standard deviations.

The deterministic components of power supply noise, of course, tend to have a fixed value which can be expressed either in terms of RMS or P-P.

The challenge in noise measurements is figuring out how much is deterministic, and therefore adds linearly, and how much is random and uncorrelated, and therefore adds in quadrature. The techniques described in this application note will help you separate the random from the deterministic sources of noise in your system.

Conclusion

Proper selection and wise operation of oscilloscopes and probes will allow you to analyze power supply noise more effectively.

Related literature

| Publication title | Publication type | Publication number |
|--------------------------------------------------------------------------------------|------------------|--------------------|
| <i>Understanding and Using Offset in InfiniiMax Active Probes</i> | Application Note | 5988-9264EN |
| <i>Performance Comparison of Differential and Single-Ended Active Voltage Probes</i> | Application Note | 5988-8006EN |
| <i>Infiniium 8000 Series Oscilloscopes</i> | Data Sheet | 5989-4271EN |
| <i>Infiniium DSO80000B Series Oscilloscopes and InfiniiMax Series Probes</i> | Data Sheet | 5989-4606EN |

Product Web site

For the most up-to-date and complete application and product information, please visit our product Web site at: www.agilent.com/find/scopes



Agilent Email Updates

www.agilent.com/find/emailupdates

Get the latest information on the products and applications you select.



Agilent Direct

www.agilent.com/find/agilentdirect

Quickly choose and use your test equipment solutions with confidence.



www.agilent.com/find/open

Agilent Open simplifies the process of connecting and programming test systems to help engineers design, validate and manufacture electronic products. Agilent offers open connectivity for a broad range of system-ready instruments, open industry software, PC-standard I/O and global support, which are combined to more easily integrate test system development.



www.lxistandard.org

LXI is the LAN-based successor to GPIB, providing faster, more efficient connectivity. Agilent is a founding member of the LXI consortium.

Remove all doubt

Our repair and calibration services will get your equipment back to you, performing like new, when promised. You will get full value out of your Agilent equipment throughout its lifetime. Your equipment will be serviced by Agilent-trained technicians using the latest factory calibration procedures, automated repair diagnostics and genuine parts. You will always have the utmost confidence in your measurements.

Agilent offers a wide range of additional expert test and measurement services for your equipment, including initial start-up assistance onsite education and training, as well as design, system integration, and project management.

For more information on repair and calibration services, go to

www.agilent.com/find/removealldoubt

www.agilent.com

For more information on Agilent Technologies' products, applications or services, please contact your local Agilent office. The complete list is available at:

www.agilent.com/find/contactus

Phone

Americas

| | |
|---------------|----------------|
| Canada | (877) 894-4414 |
| Latin America | 305 269 7500 |
| United States | (800) 829-4444 |

Asia Pacific

| | |
|-----------|----------------|
| Australia | 1 800 629 485 |
| China | 800 810 0189 |
| Hong Kong | 800 938 693 |
| India | 1 800 112 929 |
| Japan | 81 426 56 7832 |
| Korea | 080 769 0800 |
| Malaysia | 1 800 888 848 |
| Singapore | 1 800 375 8100 |
| Taiwan | 0800 047 866 |
| Thailand | 1 800 226 008 |

Europe

| | |
|----------------|-------------------------------------|
| Austria | 0820 87 44 11 |
| Belgium | 32 (0) 2 404 93 40 |
| Denmark | 45 70 13 15 15 |
| Finland | 358 (0) 10 855 2100 |
| France | 0825 010 700 |
| Germany | 01805 24 6333* *0.14€/minute |
| Ireland | 1890 924 204 |
| Italy | 39 02 92 60 8484 |
| Netherlands | 31 (0) 20 547 2111 |
| Spain | 34 (91) 631 3300 |
| Sweden | 0200-88 22 55 |
| Switzerland | (French) 44 (21) 8113811 (Opt 2) |
| Switzerland | (German) 0800 80 53 53 (Opt 1) |
| United Kingdom | 44 (0) 7004 666666 |

Other European countries:
www.agilent.com/find/contactus

Revised: March 23, 2007

Product specifications and descriptions in this document subject to change without notice.

© Agilent Technologies, Inc. 2007

Printed in USA, May 12, 2007

5989-6755EN



Agilent Technologies